

## Outdoor Utility Hybrid Cabinet: WCU1606040PONA CTV



### General Description:

The PON Active/passive Utility cabinet from Wavecom is a new modular design, specifically designed as a flexible format enclosure to house MATV/CCTV active equipment and manage 5 and 7mm microduct tubes and fibres, including splitters within the same cabinet in the field.

The cabinet is manufactured in New Zealand for the New Zealand environment and is fitted with a 40kw heat exchanger mounted into the front door.

Using a powder-coated alloy construction, it is designed to survive the harsh marine environment we live in here in New Zealand.

The cabinet can be supplied with a Mains Power Entry panel, fully compliant with New Zealand Electrical regulations NZS3000.\*

### Features:

- Powder-coated Alloy construction.
- Triple hinges & 3 point locking system for front and rear doors.
- Rear door available as left and right opening.
- IP55 sealing.
- Sealed base to eliminate any condensation issues within the cabinet.
- 40kw Heat Exchange unit mounted into the door for effective climate control.
- 6 Way Power distribution board to feed active equipment.
- Can be bolted directly to any concrete plinth or pad
- Includes flexible mounting rails
- Includes a MSS back mount to manage, 5 and 7mm tubes, splice trays, splitters and fibres (Up to 96 customers).

**Specifications:**

<b>Construction</b>	Aluminum panels fixed together with Taptight screw
<b>Finish</b>	Epoxy Powder coat
<b>Colour</b>	Light Grey RAL 7035 or Permanent Green
<b>Dimensions</b>	1600mm H x 600 W x 400 D
<b>Locking System</b>	3 point locking system with Security key via Euro 3 barrel lock front and rear doors
<b>Sealing</b>	Separate floor section to ensure the cabinet is sealed for heat exchanger efficiency

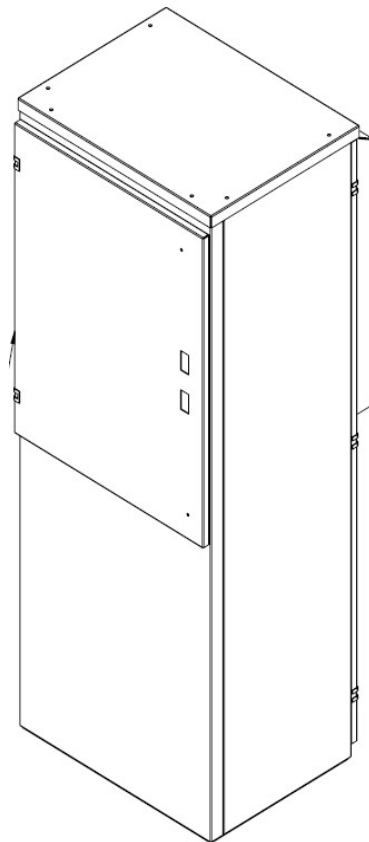
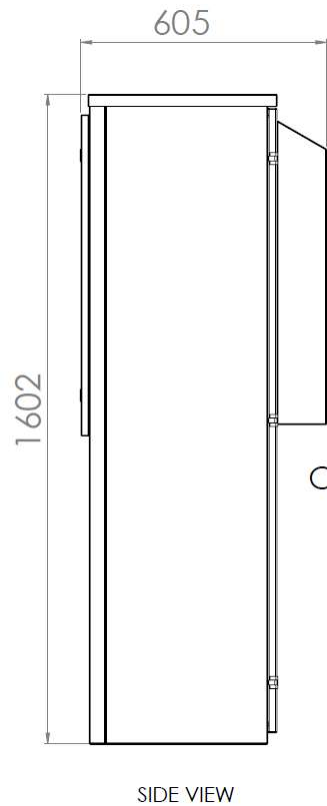
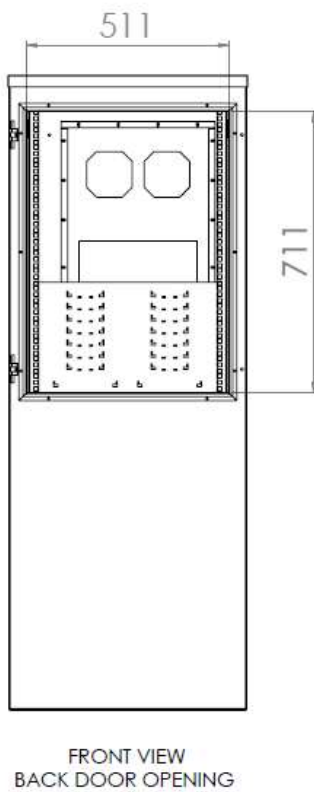
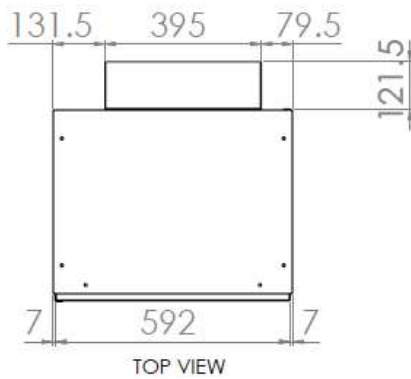

## Envicool EX Heat Exchanger.

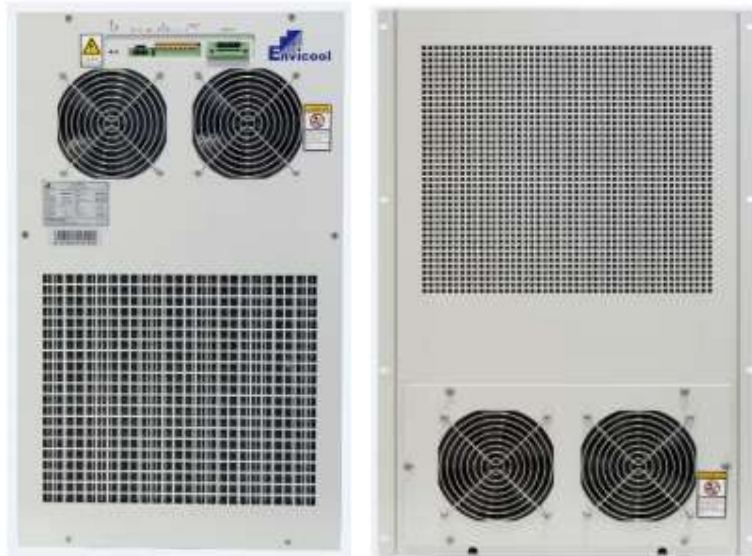

MODEL: EX04CDHC1A Envicool EX Heat Exchanger is a professional thermal control solutions provider for outdoor cabinets.

Envicool has accumulated rich technological and application experience in this field.

The EX series is the result of Envicool technology applied in DC powered outdoor Cabinet. Envicool also have many other series products for outdoor cabinet, base station usage, container applications, EC series air conditioner, DC series air conditioner, HC series combo air conditioner with heat pipes.

The EX04CDHC1A is a compact, high efficiency DC heat pipe. The design is optimized for applications with limited space available, but where functionality and performance still cannot be compromised.

- 48VDC power input
- 40W/K heat exchange capacity
- Door mounted – easy integration in outdoor cabinets
- Optional with heater
- Wide working temperature range: -40°C to +55 °C BENEFITS
- LCD Display, menu friendly
- Energy saving
- Lifetime >10 years – minimum maintenance
- Environmental friendly – RoHS2 compliant
- Resistant to corrosive environments – IP55 and Salt fog tested
- Dedicated design by delay start
- RS485 for remote control APPLICATIONS
- Telecom Cabinets
- Outdoor Radio Base Stations
- Outdoor Power Supply Cabinets
- Outdoor Gen-set Control Cabinets
- Outdoor Solar Powered Telecom Cabinets

**Specifications:**

<b>Parameter</b>	<b>Model</b>	<b>EX04CDHC1A</b>
<b>Dimensions, Weight &amp; Mount</b>		
External Dimensions (H x W x D)	mm	585×350×125
External Dimensions (H x W x D) With Flange	mm	585×388×125
Weight	kg	9
Mounting Method		Door Mounted
Application		Outdoor
<b>Environmental Protection &amp; Performance</b>		
Working Temperature Range	°C	-40 to +55
Noise Level	dB(A)	65
IP Protection Level		IP 55
Refrigerant		R134a
RoHS2 Compliant		Yes
<b>Heat Exchanged</b>		
Rated Heat Exchanged Capacity@L45/L35	W/K	40
Heating Capacity	W	/
<b>Power Consumption</b>		
Rated Fan Power	W	38
Rated Fan Current	A	0.8
<b>Airflow</b>		
Internal Airflow	m <sup>3</sup> /h	450
<b>Power Supply</b>		
Power Supply range		-44~-58VDC
Rated operating voltage - Controller	VDC	-48
Rated operating voltage - Fans	VDC	-48
Rated operating voltage - Heating (Optional)	VAC	220, 50/60
Max. Current DC	A	1.0
Max. Current AC	A	/

## Dimensions:

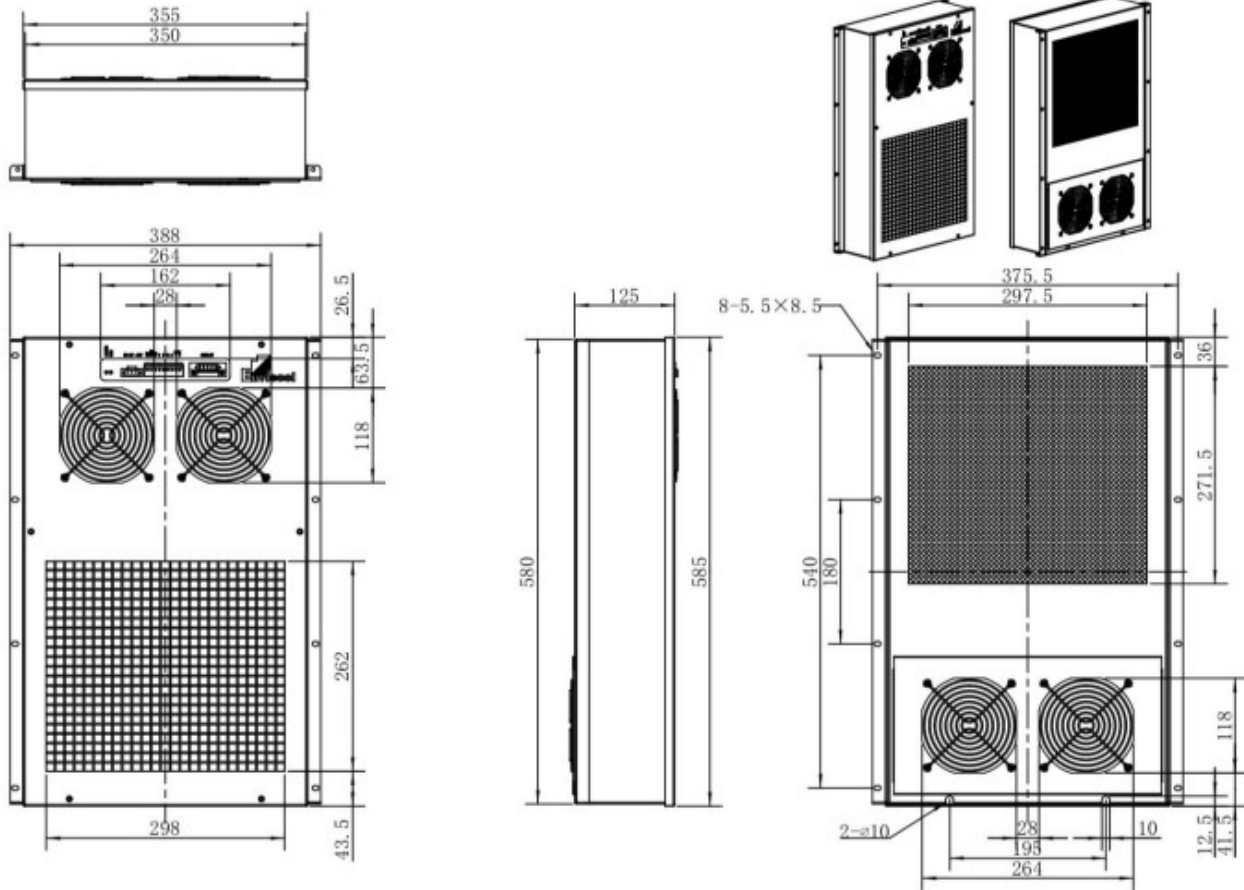

## Ordering Information:

Part Number	Product Description
WCU160604PONACTV	1600mm Utility Cabinet Hybrid Active and passive with Heat Exchange and 1050H MSS backmount. C/W Rear door.

WAVECOM-235      Stainless Steel fibre Tube bracket for 24 x 7/3.5mm tubes.



**Splice trays for OSP Cabinets, closures and Customer boxes**

Picture	Description	PN
	2 trays SE module - 12 Heat Shrink Splices per tray	WC-1380075
	4 trays SE module - 12 Heat Shrink Splices per tray (SLIM version)	WC-1380082
	5 trays SE module - 12 Heat Shrink Splices per tray	WC-1380005/12
	8 trays SE module - 12 Heat Shrink Splices per tray (SLIM version)	WC-1380083
	4 trays SC module - 4 Heat Shrink Splices per tray	WC-1380011
	8 trays SC module - 4 Heat Shrink Splices per tray	WC-1380011/8
	Holder for 3 Splitter 4x4x40 + 6 Heat Shrink Splices for tray (or, 4 Splitter 4x4x40 + 4 Heat Shrink Splices for tray)	WC-1703087
	4 trays SC DD module - 4+4 Heat Shrink Splices per tray	WC-1380081
	8 trays SC DD module - 4+4 Heat Shrink Splices per tray	WC-1380080
	Patching module for up to 6 x SC or LCD adapters	WC-1381008/2
	Patching module for up to 8 x SC or LCD adapters	WC-1381009
	Complete Fibre Distribution Device including 1 x fibre routing base 1 x Cover 2 x 16x5mm tube management clip (WC-1777403)	WC-1381005



Cover for Single Element trays	WC-1703051
Cover for Single Element SLIM trays	WC-1703097
Cover for Single Circuit trays	WC-1703047
Cover for Single Circuit DD trays	WC-1703094